

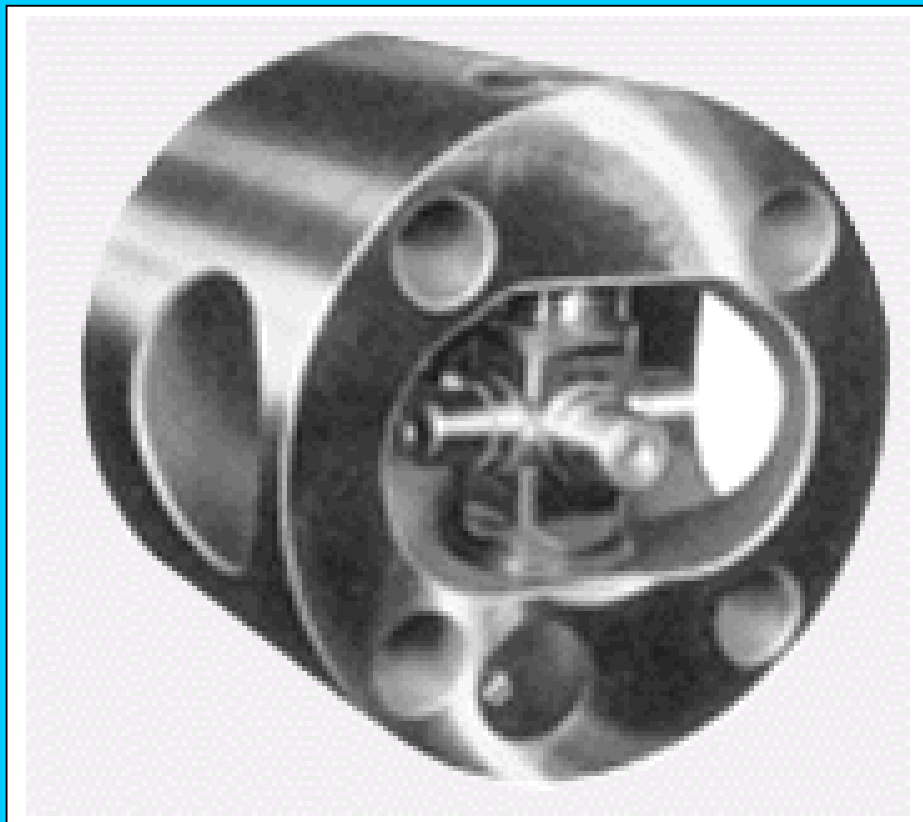

**POWER OPERATED  
POWER INDEXING CHUCK  
POPI**



## **POWER OPERATED POWER INDEXING CHUCKS**

The production and machining of components with intersecting axes has for a long time involved high processing expenditure. These components were either processed on special machines, transfer lines or on conventional lathes in several chucking operations.

GMT has developed Indexing Chucks to meet the persistent problems in machining components with intersecting axes.

GMT indexing chucks of different sizes are designed for machining typical parts like Universal joints, spider and valve bodies etc.

GMT's Power Operated Power Indexing chucks are offered with index position:

1.  $4 \times 90^{\circ}$
2.  $3 \times 120^{\circ}$
3.  $2 \times 180^{\circ}$

### **Indexing Accuracy**

Roughing: Approx. 0.1mm at 100mm from indexing centre.

Finishing: 0.03 to 0.05 at 100mm from indexing centre.

Clamping, declamping, indexing and locking of index drum are performed by integral hydraulic cylinders. The oil fed to the different cylinders through a pipe bundle running through the spindle bore.

The component is clamped by moving the lower jaw through an integral cylinder. The upper jaw is stationary. The automatic indexing chucks is hydraulically controlled through two, four-way solenoid valves. In addition the electrical circuit includes an adjustable time delay relay to incorporate short time lag between indexing and locking cycles.

The indexing is done when the main spindle is running

### **Important information required by us for preparing a quotation**

1. Component drawing with operation details.
2. Sample component.
3. Machine spindle drawing.
4. Chuck diameter.
5. Voltage and frequency for power unit & solenoid valve.

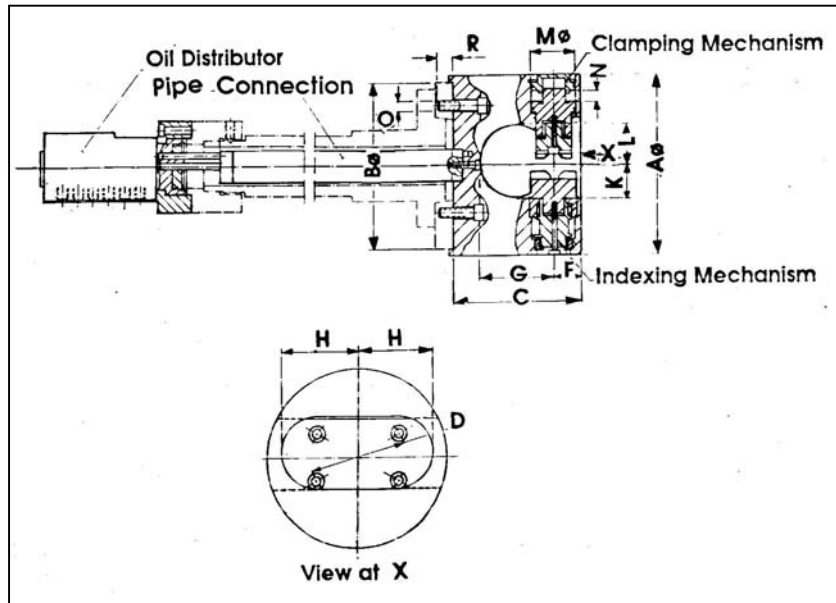

**DIMENSIONAL SPECIFICATIONS** (All dimensions are in mm)

| Model No.                           | 20-10 | 20-11 | 20-12 | 20-13 |
|-------------------------------------|-------|-------|-------|-------|
| Size $\phi$                         | 200   | 250   | 315   | 400   |
| A $\phi$                            | 200   | 250   | 315   | 400   |
| B $\phi$ H6                         | 185   | 185   | 300   | 300   |
| C                                   | 141   | 185   | 227   | 253   |
| D PCD                               | 104.8 | 133.4 | 171.4 | 171.4 |
| F                                   | 30    | 40    | 50    | 60    |
| G (Swing of the Jobs)               | 82    | 113   | 136   | 170   |
| H                                   | 85    | 106   | 136   | 170   |
| K                                   | 36.5  | 46    | 69.5  | 95    |
| L                                   | 46    | 55    | 85    | 114   |
| M $\phi$                            | 50    | 70    | 85    | 100   |
| * N (Jaw Stroke)                    | 12    | 17    | 20    | 28    |
| O                                   | 4xM10 | 4xM12 | 4xM16 | 4xM16 |
| R                                   | 15    | 18    | 27    | 25    |
| Piston Area (Cm <sup>2</sup> )      | 19.5  | 38.5  | 56.5  | 78.5  |
| Clamping force at 60 bar<br>in kgf  | 2300  | 4600  | 6800  | 9400  |
| GD <sup>2</sup> in kpm <sup>2</sup> | 0.5   | 1.5   | 5     | 12    |
| RPM Max                             | 4200  | 3600  | 2600  | 2000  |
| Wt. in kgs (approx.)                | 20    | 39    | 73    | 115   |

Note:

\* The stroke is for only one jaw. The other jaw is for indexing and will not have any axial movement.

1. Time required for indexing 1-2 secs.
2. Time required for gripping 1 sec.
3. Number of indexing available 4x90°.
4. Customer should send component drawing & spindle drawing for our study to offer suitable jaws & pipe connection.
5. Pipe connection, oil distributor and power pack should also be ordered along with chuck.



***GUINDY MACHINE TOOLS LIMITED***

*Pallikaranai, Chennai – 601302, INDIA  
Ph: +91-44-2460627 to 629, Fax: +91-44-2460112  
Email: [gmt@gmt.co.in](mailto:gmt@gmt.co.in) Web: [www.gmt.co.in](http://www.gmt.co.in)*

Due to constant development, we reserve the right to depart from our Standard Specification.